



B O S
LIGHTING

HP7 QUAD 350



MAKE LIFE BRIGHTER



CONTACT

Address

BOS Lighting
Meerheide 60
5521 DZ Eersel
The Netherlands



Online

Emergency email
Email
Website

sos@bos-lighting.nl
info@bos-lighting.nl
www.bos-lighting.nl



TABLE OF CONTENTS

SAFETY INSTRUCTIONS & MAINTENANCE	PAGE 3
INSTALLATION	PAGE 4
<i>WHAT IS IN THE BOX?</i>	PAGE 4
<i>DIMENSIONS P7 HEX</i>	PAGE 4
<i>PREPARING</i>	PAGE 4
<i>IP 20</i>	PAGE 5
DMX-512 CONTROL CONNECTIONS	PAGE 6
PHOTOMETRIC DATA	PAGE 7
MENU OVERVIEW	PAGE 8
DMX CHANNELS	PAGE 9
<i>17 CH MODE</i>	PAGE 9
<i>22 CH MODE</i>	PAGE 11
TROUBLESHOOTING AND CLEANING	PAGE 13
TECHNICAL SPECIFICATIONS	PAGE 14

This product is for professional use only. It is not for household use.

This product presents risks of severe injury or death due to fire and burn hazards, electric shock and falls. Read this manual before installing, powering or servicing the fixture, follow the safety precautions listed below and observe all warnings in this manual and printed on the fixture. This device has left the factory in perfect condition. In order to maintain this condition and to ensure a safe operation, it is absolutely necessary for the user to follow the safety instructions and warning notes written in this user manual.

If you have questions about how to operate the fixture safely, please contact us via info@bos-lighting.nl.



WARNING!

Read the safety precautions in this section before unpacking, installing, powering or operating this product.

- This luminaries are multi-environmental fixtures with an IP-rating of 65, intended for professional use only. They are not suitable for household use.
- Review the following safety precautions carefully before installing or operating the fixture. This fixture must be installed in accordance with the applicable installation code by a person familiar with the construction and operation of the fixture and the hazards involved.



WARNING!

Risk of electric shock.

- Always power off/unplug the fixture before removing any covers.
- Ensure that the power is turned off when connecting the fixture to the AC mains supply.
- Do not apply power if the fixture is in any way damaged.
- Do not immerse the fixture in water or liquid.



WARNING!

Take measures to prevent burns and fire.

- Install in a location that prevents accidental contact with the fixture.
- Install only in a well-ventilated space.
- Install at least 0.3 m (12 in.) away from objects to be illuminated.
- Install only in accordance with applicable building codes.
- Ensure a minimum clearance of 0.1 m (4 in.) around the cooling fans.
- Do not paint, cover or modify the fixture.
- Keep all flammable materials away from the fixture.
- Allow the fixture to cool for 15 minutes after operation, before touching it.
- CAUTION: Exterior surface temperature after 5 min. operation = 45 °C



WARNING!

Take measure to prevent personal injury.

- Do not look directly at the light source from close range.
- Take precautions to prevent injury due to falls when working at height.
- For permanent installation, ensure that the fixture is securely fastened to a load-bearing surface with suitable corrosion-resistant hardware.
- For temporary installation with clamps, ensure that the quarter-turn fasteners are turned fully and secured with a suitable safety cable.
- The cable must be approved for a safe working load (SWL) of 10 times the weight of the fixture, and it must have a minimum gauge of 3 mm.



CAUTION!

Disconnect from mains before starting maintenance operation

The following points have to be considered during the inspection:

1. All screws for installing the devices or parts of the device have to be tightly connected and must not be corroded.
2. There must not be any deformations on the housing, color lenses, fixations and installation spots (ceiling, suspension, trussing).
3. Mechanically moved parts must not show any traces of wearing and must not rotate with unbalances.
4. The electric power supply cables must not show any damage, material fatigue or sediments.

Further instructions depending on the installation spot and usage have to be adhered by a skilled installer and any safety problems have to be removed.

SECTION 2 INSTALLATION

WHAT IS IN THE BOX?

- 1x HP7 QUAD 350
- 1x Shuko -> True1
- 1x Safety cable
- 1x Quicklock bracket for clamp

DIMENSIONS HP7 QUAD 350



PREPARING

Unpack the fixture and inspect it to ensure that it has not been damaged during transport. Read the manual before installation.

When selecting a location for the fixture, ensure that:

- It is situated away from public thoroughfares and protected from contact with people.
- It is not immersed in water or exposed to high-pressure water jets.
- It has adequate ventilation.



IP 20

SOLIDS

1	Protected against a solid object greater than 50mm such as a hand.
2	Protected against a solid object greater than 12.5mm such as a finger.
3	Protected against a solid object greater than 2.5mm such as a screwdriver.
4	Protected against a solid object greater than 1mm such as a wire.
5	Dust protected. Limited ingress of dust permitted. Will not interfere with operation of the equipment.
6	Dust tight. No ingress of dust.

LIQUIDS

1	Protected against vertical falling drops of water. Limited ingress permitted.
2	Protected against vertical falling drops of water with enclosure tilted up to 15 degrees from the vertical. Limited ingress permitted.
3	Protected against sprays of water up to 60 degrees from the vertical. Limited ingress permitted.
4	Protected against water splashes from all directions. Limited ingress permitted.
5	Protected against jets of water. Limited ingress permitted.
6	Protected against powerful jets of water. Limited ingress permitted.
7	Protected against the effects of immersion in water between 15cm and 1m for 30 minutes.
8	Protected against the effects of immersion in water under pressure for long periods.

Ingress Protection

2 0



WARNING!

Make sure the manual is read, and followed, before usage of the product.

IP65 is not waterproof – it is water resistant. Products that carry an IP65 rating cannot be submerged and maintain their protections.

The purpose of the HP7 QUAD 350 is for temporary use. The products purpose is for e.g. festivals, theatres, indoor and outdoor concerts. Long term usage can lead to damage due to aging of the materials and affecting the coated surface, and the rubber sealings will be affected by long-term UV exposure. Tightening the screws to hard will affect the IP-rating. Please make sure the cleaning and maintaining procedures are in order for a safe environment.



SECTION 3 DMX-512 CONTROL CONNECTIONS

SECTION 4 PHOTOMETRIC DATA

Connect the provided XLR cable to the female 3-pin XLR & 5-pin XLR output of your controller and the other side to the male 3-pin XLR & 5-pin XLR input of the moving head. You can chain multiple moving head together through serial linking. The cable needed should be two core, screened cable with XLR input and output connectors. Please refer to the diagram below.

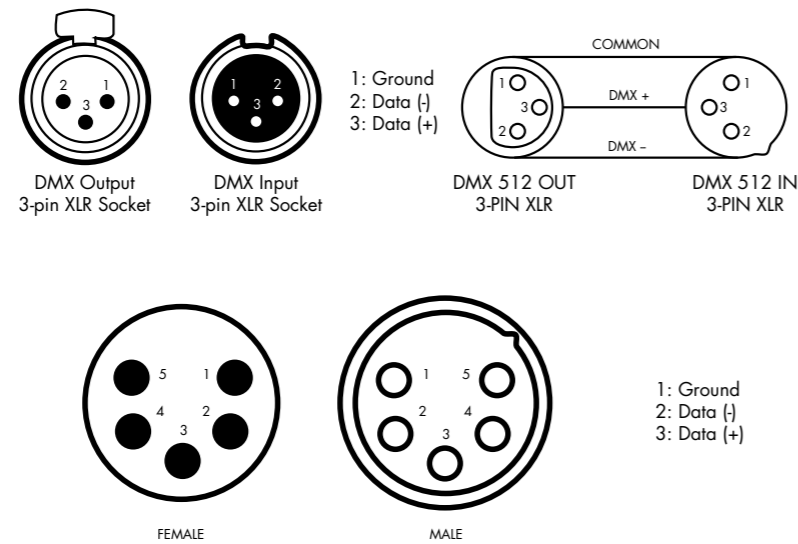

For installations where the DMX cable has to run a long distance or is in an electrically noisy environment, such as in a discotheque, it is recommended to use a DMX terminator. This helps in preventing corruption of the digital control signal by electrical noise. The DMX terminator is simply an XLR plug with a 120 Ω resistor connected between pins 2 and 3, which is then plugged into the output XLR socket of the last fixture in the chain.

Please see illustrations below.

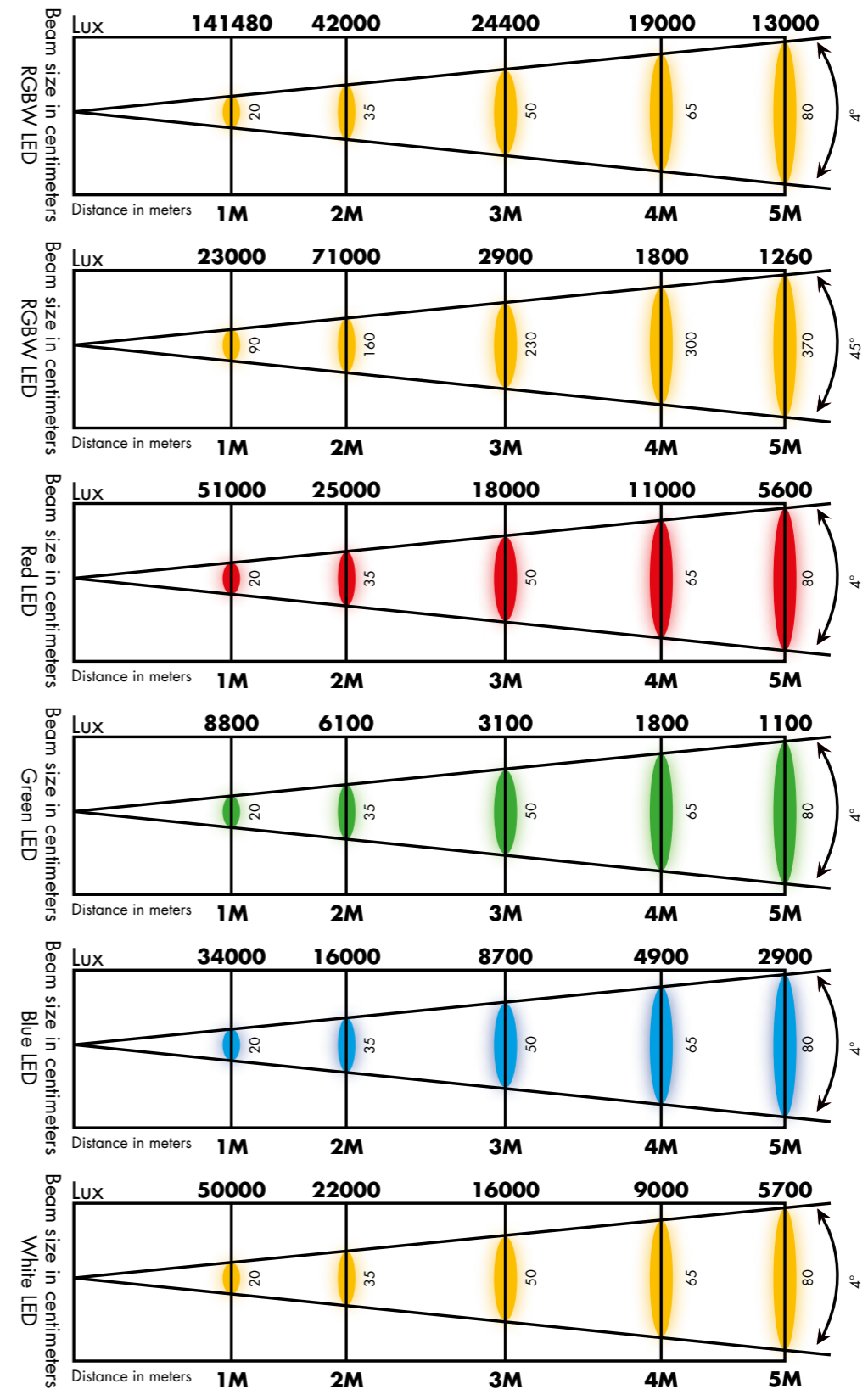
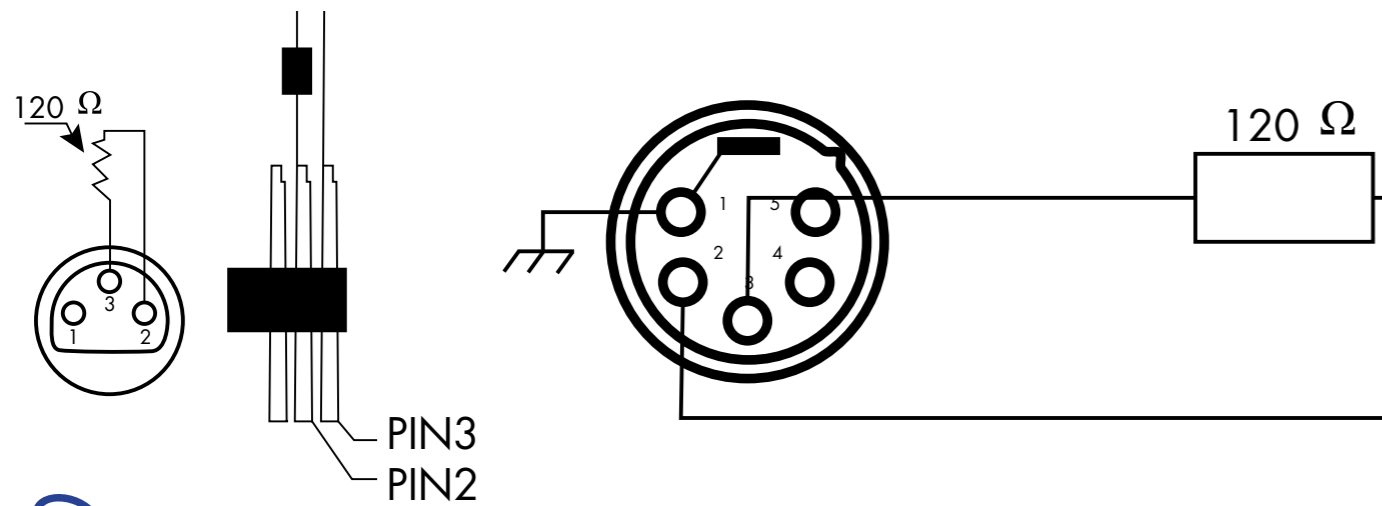



SECTION 5 MENU OVERVIEW

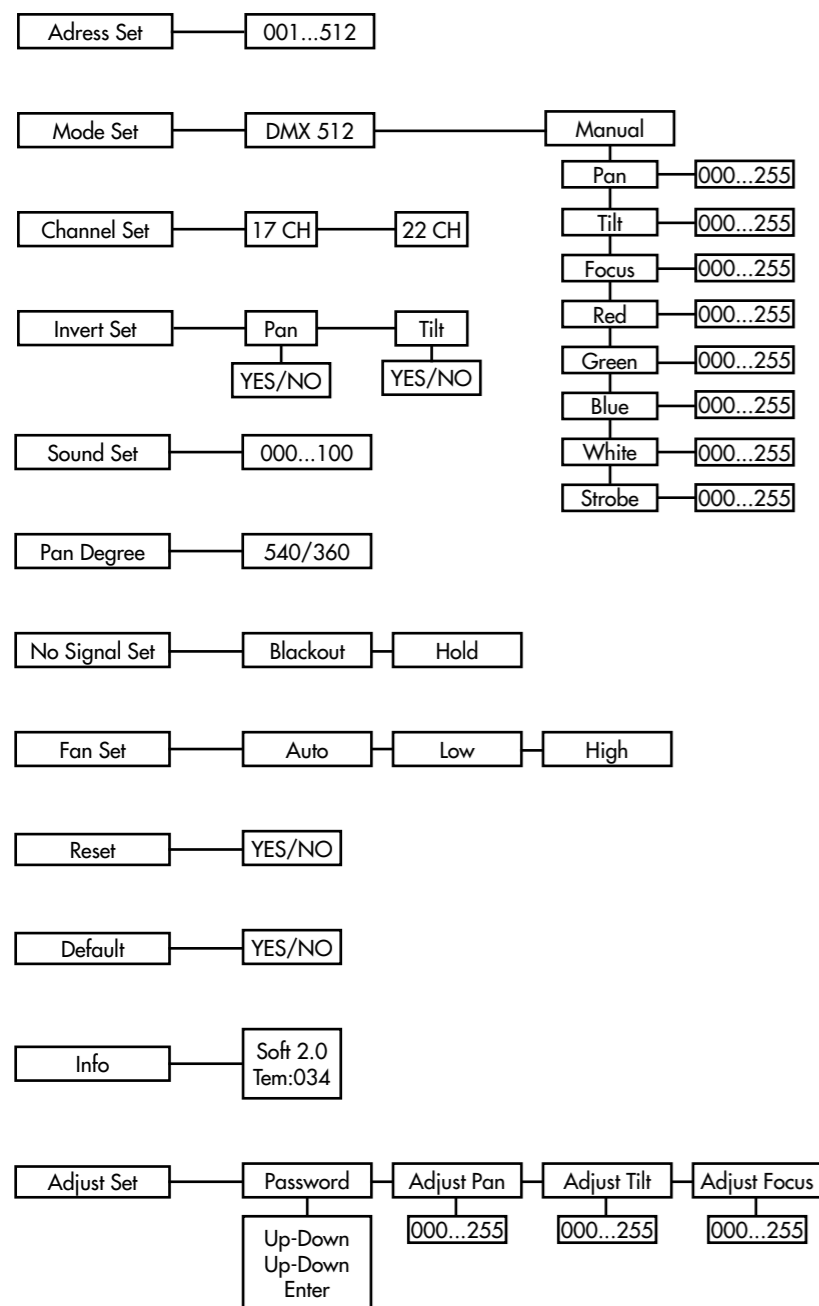

SECTION 6 DMX CHANNELS

17 CH MODE

Channel	Value	Function
1	000...255	Pan adjustment
2	000...255	Pan fine adjustment
3	000...255	Tilt adjustment
4	000...255	Tilt fine adjustment
5	000...255	Speed of pan/tilt fast (0) to slow (255)
Strobe Effect		
6	000...003	Turn on the light
	004...203	Synchro Speed slow (4) to fast (203) - 1HZ to 25HZ
	204...255	Random strobe
7	000...255	Dimmer from dark (0) to bright (255)
Dimming Mode		
8	000...049	Mode 1
	050...099	Mode 2
	100...149	Mode 3
	150...255	Mode 4
9	000...255	Zoom from near (0) to far (255)
10	000...255	RED from dark (0) to bright (255)
11	000...255	GREEN from dark (0) to bright (255)
12	000...255	BLUE from dark (0) to bright (255)
13	000...255	WHITE from dark (0) to bright (255)
Static Color		
14	000...015	No function
	016...035	RED 100% - GREEN up, BLUE 0%
	036...055	RED down - GREEN 100% - BLUE 0%
	056...075	RED 0% - GREEN 100% - BLUE up
	076...095	RED 0% - GREEN down - BLUE 100%

14	96...115	RED up - GREEN 0% - BLUE 100%
	116...135	RED 100% - GREEN up - BLUE down
	136...155	RED 100% down - GREEN up - BLUE up
	156...175	RED down - GREEN down - BLUE 100%
	176...195	RED 100% - GREEN 100% - BLUE 100% - WHITE 100%
	196...200	2800K
	201...205	3200K
	206...210	4000K
	211...215	4500K
	216...220	5000K
	221...225	5600K
	226...230	6500K
	231...235	7000K
	236...240	7500K
241...255	8000K	
15	Moving Color	
	000...049	No function
	050...099	Skip change
	100...255	Gradual change
16	000...255	Speed of moving color from fast (0) to slow (255)
17	Reset	
	000...250	No function
	251...255	Reset 5s

22 CH MODE

Channel	Value	Function
1	000...255	Pan adjustment
2	000...255	Pan fine adjustment
3	000...255	Tilt adjustment
4	000...255	Tilt fine adjustment
5	000...255	Speed of pan/tilt fast (0) to slow (255)
6	000...255	Zoom from near (0) to far (255)
7	000...255	Dimmer from dark (0) to bright (255)
8	000...255	Dimming adjustment control
9	Strobe Effect	
	000...003	Turn on the light
	004...203	Synchro Speed slow (4) to fast (203) - 1HZ to 25HZ
	204...255	Random strobe
10	000...255	RED from dark (0) to bright (255)
11	000...255	RED fine adjustment
12	000...255	GREEN from dark (0) to bright (255)
13	000...255	GREEN fine adjustment
14	000...255	BLUE from dark (0) to bright (255)
15	000...255	BLUE fine adjustment
16	000...255	WHITE from dark (0) to bright (255)
17	000...255	WHITE fine adjustment
18	Dimming Mode	
	000...049	Linear
	050...099	Exponential
	100...149	Logarithmic
	150...255	S-Curve



SECTION 7 TROUBLESHOOTING AND CLEANING

Static Color		
000...015	No function	
016...035	RED 100% - GREEN up, BLUE 0%	
036...055	RED down - GREEN 100% - BLUE 0%	
056...075	RED 0% - GREEN 100% - BLUE up	
076...095	RED 0% - GREEN down - BLUE 100%	
096...115	RED up - GREEN 0% - BLUE 100%	
116...135	RED 100% - GREEN up - BLUE down	
136...155	RED 100% down - GREEN up - BLUE up	
156...175	RED down - GREEN down - BLUE 100%	
176...195	RED 100% - GREEN 100% - BLUE 100% - WHITE 100%	
196...200	2800K	
201...205	3200K	
206...210	4000K	
211...215	4500K	
216...220	5000K	
221...225	5600K	
226...230	6500K	
231...235	7000K	
236...240	7500K	
241...255	8000K	
Moving Color		
000...049	No function	
050...099	Skip change	
100...255	Gradual change	
21	000...255	Speed of moving color from fast (0) to slow (255)
Reset		
22	000...250	No function
22	251...255	Reset 5s



CAUTION!

Disconnect from mains before starting maintenance operation

The lamp contains professional components such as microcomputer circuit board and high-voltage power supply. For your safety and product life, non-professionals should not disassemble the lamp and related accessories without authorization.

The bulb does not light up (except LED light source)

Possible cause: The bulb is not completely cooled, or the bulb has reached the end of its life, the treatment is as follows:

- Due to abnormal operation, the bulb is not completely cooled down, so let the lamp body cool down for more than 10 minutes to make the inside completely return to normal state, and then turn on the power again.
- Check whether the bulb has reached the end of its life, and replace it with a new one.
- Check whether the bulb and the lighter circuit are leaking, falling off, or having poor contact.
- Replace with a new light source.

The light beam appears dim

Possible cause: The bulb has been used for a long time or the light path is not clean, the treatment is as follows:

- Check whether the bulb has reached the end of its life, and replace it with a new one
- Check whether the optical components or bulbs are clean, and whether there is dust on the bulbs and other optical components.
- Regular cleaning and maintenance of the bulbs and components in the lamps are required.

Blurred pattern projection

Possible cause: Lenses are dirty or electronic focus is defect:

- Check if lenses are clean.
- Check whether the electronic focus channel value is suitable for the current projection distance.

The lamps work intermittently

Possible cause: The internal circuit enters the protection state, and the treatment is as follows

- Check whether the fan is operating normally or whether it is dirty, causing the internal temperature of the lamp to rise
- Check whether the internal temperature control switch is closed
- Check whether the bulb has reached the end of its service life, and replace it with a new one.

After the lamp is reset normally, it does not accept the control of the console

Possible cause: signal line failure or abnormal lamp parameter setting, the treatment is as follows:

- Check the start address code and check the connection of the DMX signal line (whether the signal line cable is intact, and whether the connection of the head is loose)
- Add signal amplifier, add 120 ohm terminal resistance.

The lamp can't start

Possible cause: bad power line, the treatment is as follows:

- Check whether the fuse on the power input socket is fused, replace the fuse.
- Lamps have poor line contact due to vibration during long-distance transportation.
- Check the input power, computer board and other plug-in devices.



CAUTION!

Disconnect from mains before starting cleaning operation

In order to make the lights in good condition and extend the life time, we suggest a regular cleaning to the lights.

1. Clean the inside and outside lens each week to avoid the weakness of the lights due to accumulation of dust.
2. Clean the fan each week.
3. A detailed electric check by approved electrical engineer each three month, make sure that the circuit contacts are in good condition, prevent the poor contact of circuit from overheating.

We recommend a frequent cleaning of the device. Please use a moist, lint-free cloth. Never use alcohol solvents.

There are no serviceable parts inside the device. Please refer to the instructions under "Installation instructions". Should you need any spare parts, please order genuine parts from your local dealer.

SECTION 8 TECHNICAL SPECIFICATIONS

Light Source	7 × 4in1 RGBW LED, each 40 W	
Optical properties	Beam angle	4° - 45°
	Repetition rate	3000 Hz
Control	DMX	
	Buttons and display	
	Infrared remote control	
Number of DMX channels	17CH, 22CH	
Power connections	Lockable True1 In/Out	
Control connections	DMX control	3-pin XLR In/Out
Power consumption	250W	
Operating supply voltage	100 – 240 V 50/60 Hz	
Protection class	IP20	
Mounting options	Hanging, standing	
Dimensions (W × H × D), with bracket	258 mm × 344 mm × 166 mm	
Weight	6 kg	
Ambient conditions	Temperature range	0 °C...40 °C
	Relative humidity	20 %...80 % (non-condensing)
Construction	Outdoor housing, PAR	
Number of LEDs	7	
Color mixture	RGBW	
LED type	4 -in- 1	
Floor housing	Yes	
Fanless	No	
Wireless DMX	No	
Housing color	Black	

